

# LCD Module Technical Specification

First Edition  
May. 11, 2010

Final Revision  
Nov. 11, 2010

---

Type No. **T-55562D090J-LW-A-ABN**

---

Customer :

Customer's Product No :

## OPTREX CORPORATION

Approved : *Yasuo Kawasaki*  
*QUALITY ASSURANCE DIVISION*

---

Checked : *Toshiaki Ochi*  
*Product Realization Div.*

---

Prepared : *Noboru Wada*  
*Product Realization Div.*

---

**APPROVED**

By \_\_\_\_\_

Signature :

Date :

Please return this specification within two month with your signature.  
If not returned within two month ,specification will be considered  
as having been accepted.

# CONTENTS

No.	Item	Page
--	CONTENTS	2
1	APPLICATION	3
2	OVERVIEW	4
3	ABSOLUTE MAXIMUM RATINGS	5
4	ELECTRICAL CHARACTERISTICS	5
5	INTERFACE PIN CONNECTION	8
6	INTERFACE TIMING	11
7	BLOCK DIAGRAM	16
8	MECHANICAL SPECIFICATION	17
9	OPTICAL CHARACTERISTICS	22
10	RELIABILITY TEST CONDITION	25
11	INSPECTION STANDARDS	26
12	OTHER FEATURE	27
13	HANDLING PRECAUTIONS FOR TFT-LCD MODULE	28
--	PACKAGING SPECIFICATION	31
--	PRODUCTS NUMBER LABELING FORMS	35
--	LED UNIT for 9.0" WVGA	36

## Revision History

Rev.	Date	Comment
1	Nov. 11, 2010	Revise: TECHNICAL SPECIFICATION Revise: LED UNIT for 9.0" WVGA

T-55562D090J-LW-A-ABN Rev.1	OPTREX CORPORATION	Page 2/41
-----------------------------	--------------------	-----------

# 1. APPLICATION

This specification applies to color TFT-LCD module, T-55562D090J-LW-A-ABN.

These specification papers are the proprietary product of OPTREX CORPORATION (“OPTREX”) and include materials protected under copyright of OPTREX. No part of this document may be reproduced in any form or by any means without the express written permission of OPTREX.

OPTREX does not assume any liability for infringement of patents, copyrights or other intellectual property rights of third parties by or arising from use of a product specified in this document. No license, express, implied or otherwise, is granted under any patents, copyrights or other intellectual property rights of OPTREX or of others.

OPTREX classifies the usage of the TFT-LCD module as follows. Please confirm the usage before using the product.

## (1) Standard Usage

Computers, office equipment, factory automation equipment, test and measurement equipment, communications, transportation equipment(automobiles, ships, trains, etc.), provided, however, that operation is not influenced by TFT-LCD directly.

## (2) Special Usage

Medical equipment, safety equipment, transportation equipment, provided, however, that TFT-LCD is necessary to its operation.

## (3) Specific Usage

Cockpit Equipment, military systems, aerospace equipment, nuclear reactor control systems, life support systems and any other equipment. OPTREX should make a contract that stipulate apportionment of responsibilities between OPTREX and our customer.

The product specified in this document is designed for “Standard Usage” unless otherwise specified in this document. If customers intend to use the product for applications other than those specified for “Standard Usage”, they should first contact OPTREX sales representative for it's intended use in writing.

OPTREX has been making continuous effort to improve the reliability of its products. Customers should implement sufficient reliability design of their application equipments such as redundant system design, fail-safe functions, anti-failure features.

OPTREX assumes no responsibility for any damage resulting from the use of the product that does not comply with the instructions and the precautions specified in this document.

Please contact and consult OPTREX sales representative for any questions regarding this product.

T-55562D090J-LW-A-ABN Rev.1	OPTREX CORPORATION	Page 3/41
-----------------------------	--------------------	-----------

## 2. OVERVIEW

T-55562D090J-LW-A-ABN is 9.0" color TFT-LCD (Thin Film Transistor Liquid Crystal Display) module composed of LCD panel, driver ICs, control circuit, backlight unit, and touch panel.

By applying 6 bit or 8 bit digital data, 800 × 480, 262k-color or 16.7M-color images are displayed on the 9.0" diagonal screen. Input power voltage is 3.3V for LCD driving.

The type of data and control signals are digital and transmitted via LVDS interface per Typ. 30.4 MHz clock cycle.

Driver circuit for LED backlight and controller for touch panel are not included in this module. General specifications are summarized in the following table:

ITEM	SPECIFICATION
Display Area (mm)	196.8 (H) × 118.08 (V) (9.0-inch diagonal)
Number of Dots	800 × 3 (H) × 480 (V)
Pixel Pitch (mm)	0.246 (H) × 0.246 (V)
Color Pixel Arrangement	RGB vertical stripe
Display Mode	Normally white
Number of Color	262k(6 bit/color), 16.7M(8 bit/color)
Luminance (cd/m <sup>2</sup> )	640
Viewing Angle (CR ≥ 10)	-80~80°(H), -60~80°(V)
Surface Treatment (Touch panel)	Anti-glare and hard-coating 3H
Electrical Interface	LVDS (6 bit/8 bit)
Viewing Direction	Higher Contrast ratio: 6 o'clock Less gray scale reversal: 12 o'clock
Module Size (mm)	219.0 (W) × 136.2 (H) × 11.1 (D)
Module Mass (g)	420
Backlight Unit	LED, edge-light, replaceable
Touch panel	4-wire analog resistive

Characteristic value without any note is typical value.

### 3. ABSOLUTE MAXIMUM RATINGS

ITEM	SYMBOL	MIN.	MAX	UNIT
Power Supply Voltage for LCD	VCC	0	4.0	V
Logic Input Voltage	VI	-0.3	VCC+0.3	V
Backlight (LED) Current	IF	0	180	mA
Touch Panel Voltage	TPV	--	7.0	V
Operation Temperature (Touch Panel) <small>Note 1,2)</small>	T <sub>op(TouchPanel)</sub>	-20	70	°C
Operation Temperature (Ambient) <small>Note 2)</small>	T <sub>op(Ambient)</sub>	-20	70	°C
Storage Temperature <small>Note 2)</small>	T <sub>stg</sub>	-30	80	°C

[Note]

1) Measured at the center of active area and at the center of panel back surface

2) Top, Tstg ≤ 40°C : 90%RH max. without condensation

Top, Tstg > 40°C : Absolute humidity shall be less than the value of 90%RH at 40°C without condensation.

### 4. ELECTRICAL CHARACTERISTICS

(1) TFT-LCD

Ambient temperature: Ta = 25°C

ITEM	SYMBOL	MIN.	TYP.	MAX.	UNIT	Remarks
Power Supply Voltages for LCD	VCC	3.0	3.3	3.6	V	*1)
Power Supply Currents for LCD	ICC	--	340	500	mA	*2)
Permissive Input Ripple Voltage	VRP	--	--	100	mVp-p	VCC = +3.3V
Logic Input Voltage	High	VIH	0.8×VCC	--	VCC	MODE, SC
	Low	VIL	0	--	0.2×VCC	MODE, SC

\*1) Power and signals sequence:

$$\begin{aligned}
 t1 &\leq 10 \text{ ms} & 200 \text{ ms} &\leq t4 \\
 0 < t2 &\leq 50 \text{ ms} & 200 \text{ ms} &\leq t5 \\
 0 < t3 &\leq 50 \text{ ms} & 0 &\leq t6
 \end{aligned}$$

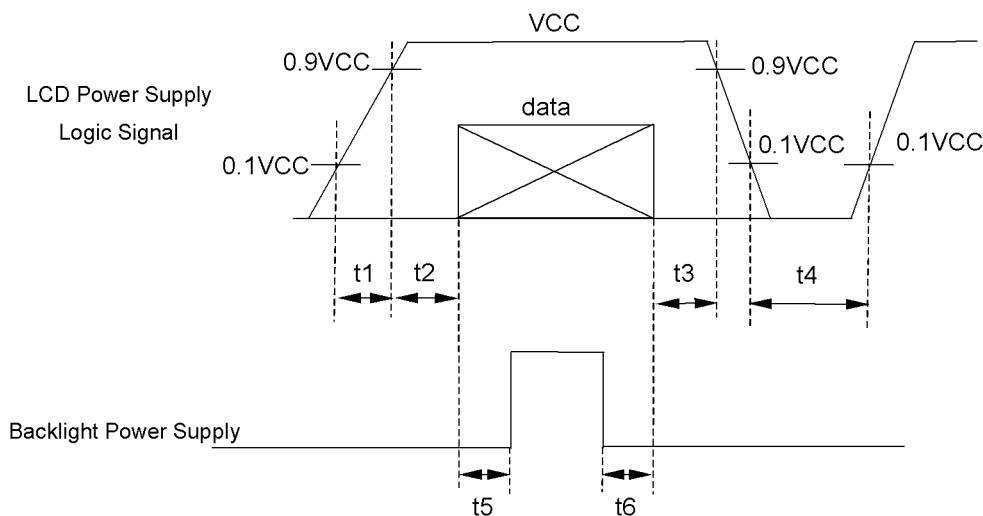

data: RGB DATA, DCLK, DENA, MODE, SC

VCC-dip conditions:

- 1) When  $2.6\text{ V} \leq VCC < 3.0\text{ V}$ ,  $t_d \leq 10\text{ ms}$
- 2) When  $VCC < 2.6\text{ V}$

VCC-dip conditions should also follow the power and signals sequence.

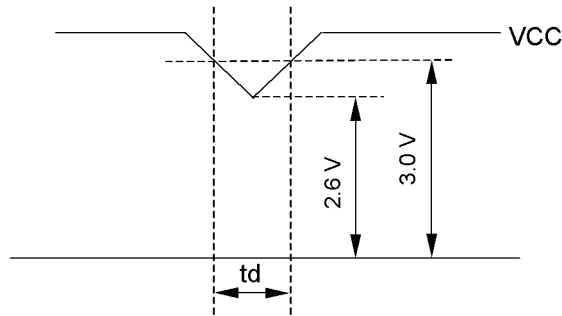

\*2)  $VCC = +3.3\text{ V}$ ,  $f_H=31.7\text{ kHz}$ ,  $f_V=60\text{ Hz}$ ,  $f_{CLK}=30.4\text{ MHz}$

Display image at typical power supply current value is 256-gray-bar pattern (8 bit), 480 line mode.

\*3) Fuse

Parameter	Fuse Type Name	Supplier	Remark
VCC	FCC16162AB	Kamaya Electric Co., Ltd.	*)

\*) The power supply capacity should be designed to be more than the fusing current.

(2) Backlight

$T_a = 25^\circ\text{C}$

ITEM	SYMBOL	MIN.	TYP.	MAX.	UNIT	Remarks
LED Voltage	VF	--	(24)	29.9	V	$I_F = 80\text{ mA}$ , $T_a = 25^\circ\text{C}$ , *2)
		--	--	31.0	V	$I_F = 80\text{ mA}$ , $T_a = 0^\circ\text{C}$
		--	--	31.9	V	$I_F = 80\text{ mA}$ , $T_a = -20^\circ\text{C}$
LED Current	IF	--	80	90	mA	$T_a = 25^\circ\text{C}$ , *1), *3)
LED Life Time	LT	80,000	100,000	--	h	$I_F = 80\text{ mA}$ , $T_a = 25^\circ\text{C}$ *4), *5), Continuous operation

[Note]

\*1) Constant Current Drive

\*2) The Voltage deviation between strings:  $|V_{f1} - V_{f2}| \leq 2\text{V}$

\*3) LED Current measurement method

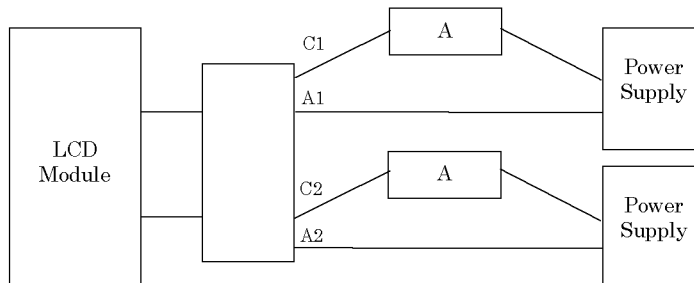

\*4) LED life time is defined as the time when the brightness becomes 50% of the initial value.

\*5) The life time of the backlight depends on the ambient temperature. The life time will decrease under low/high temperature.

(3) Touch Panel

Electrical Characteristics

ITEM	MIN.	TYP.	MAX.	UNIT	Remarks
Linearity	-1.5	--	1.5	%	Analog X and Y directions
Terminal Resistance	527	--	1231	$\Omega$	X
	186	--	434	$\Omega$	Y
Insulation Resistance	20	--	--	M $\Omega$	DC 25 V
Voltage	3.0	5.0	7.0	V	DC
Chattering	--	--	10	ms	

\*) Do not operate it with a thing except a polyacetal pen (tip R0.8 mm or more) or a finger, especially those with hard or sharp tips such as a ball point pen or a mechanical pencil.

## 5. INTERFACE PIN CONNECTION

### (1) CN 1(Interface Signal)

Used connector: FI-SE20P-HFE (JAE)

Corresponding connector: FI-S20S[for discrete Wire], FI-SE20ME[for FPC] (JAE)

Pin No.	Symbol	Function (ISP 6 bit compatibility mode)		Function (ISP 8 bit compatibility mode)
		6 bit input	8 bit input	
1	VCC	+3.3 V Power supply		←
2	VCC	+3.3 V Power supply		←
3	GND	GND		←
4	GND	GND		←
5	Link 0-	R0, R1, R2, R3, R4, R5, G0	R2, R3, R4, R5, R6, R7, G2	R0, R1, R2, R3, R4, R5, G0
6	Link 0+	R0, R1, R2, R3, R4, R5, G0	R2, R3, R4, R5, R6, R7, G2	R0, R1, R2, R3, R4, R5, G0
7	GND	GND		←
8	Link 1-	G1, G2, G3, G4, G5, B0, B1	G3, G4, G5, G6, G7, B2, B3	G1, G2, G3, G4, G5, B0, B1
9	Link 1+	G1, G2, G3, G4, G5, B0, B1	G3, G4, G5, G6, G7, B2, B3	G1, G2, G3, G4, G5, B0, B1
10	GND	GND		←
11	Link 2-	B2, B3, B4, B5, DENA	B4, B5, B6, B7, DENA	B2, B3, B4, B5, DENA
12	Link 2+	B2, B3, B4, B5, DENA	B4, B5, B6, B7, DENA	B2, B3, B4, B5, DENA
13	GND	GND		←
14	CLKIN-	Clock -		←
15	CLKIN+	Clock +		←
16	GND	GND		←
17	Link3-	See: *2)	R0, R1, G0, G1, B0, B1	R6, R7, G6, G7, B6, B7
18	Link3+	See: *2)	R0, R1, G0, G1, B0, B1	R6, R7, G6, G7, B6, B7
19	MODE	Low=ISP 6 bit compatibility mode		High=ISP 8 bit compatibility mode
20	SC	Scan direction control (Low=Normal, High=Reverse)		←

\*1) Metal frame is connected to signal GND.

\*2) Recommended wiring of Pin 17,18 (6 bit input)

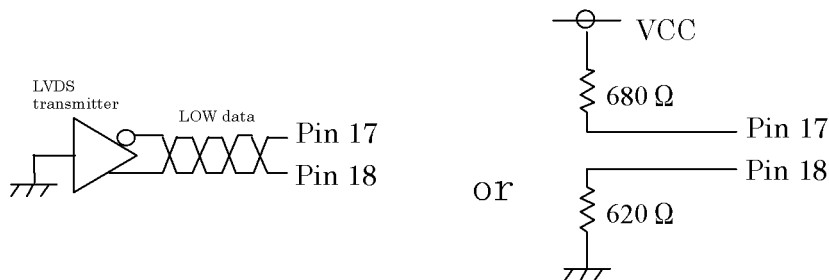

### (2) CN 2(Backlight)

Backlight-side connector: SM06B-SHLS-TF(LF)(SN) (JST)

Corresponding connector: SHLP-06V-S-B (JST)

Pin No.	Symbol	Function
1	NC	This pin should be open.
2	NC	This pin should be open.
3	LED C 1	LED cathode 1
4	LED A 1	LED anode 1
5	LED A 2	LED anode 2
6	LED C 2	LED cathode 2

(3) FPC 1 (Touch Panel Interface)

Pin No.	Symbol
1	XL
2	YU
3	XR
4	YD

(4) Touch Panel

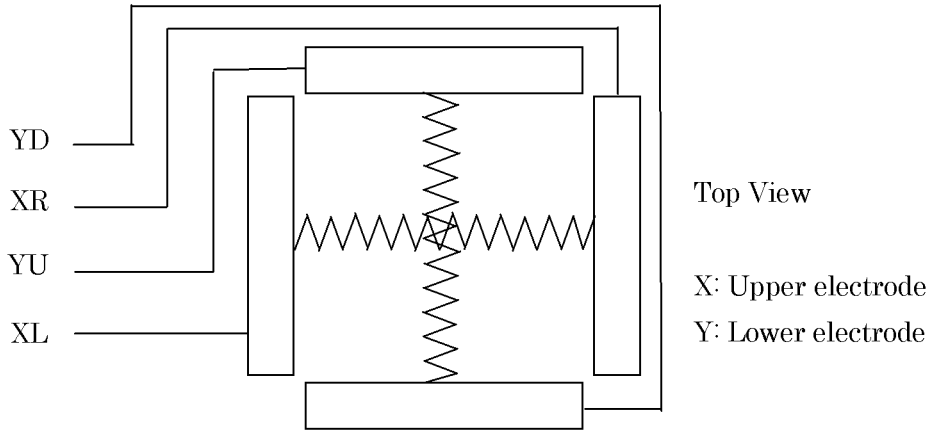

### (5) ISP data mapping

#### a. ISP 6 bit compatibility mode(6 bit input)

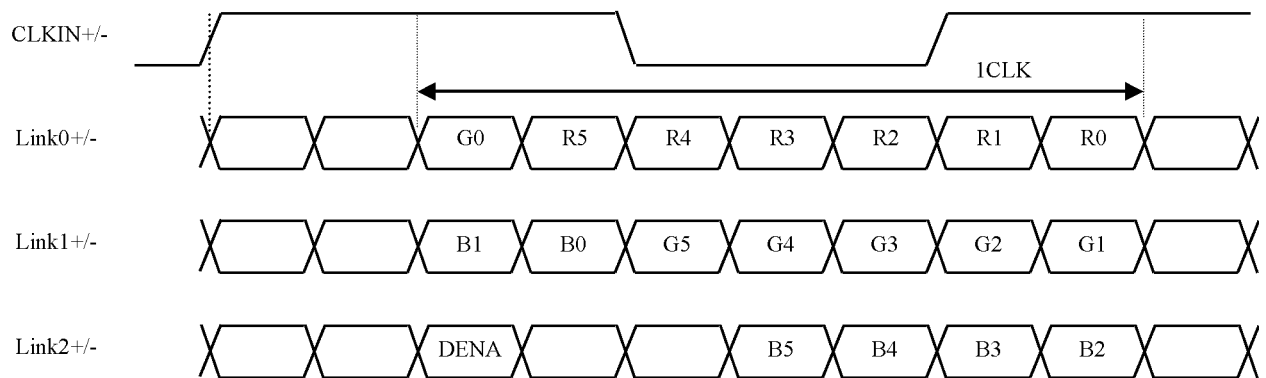

#### b. ISP 6 bit compatibility mode(8 bit input)

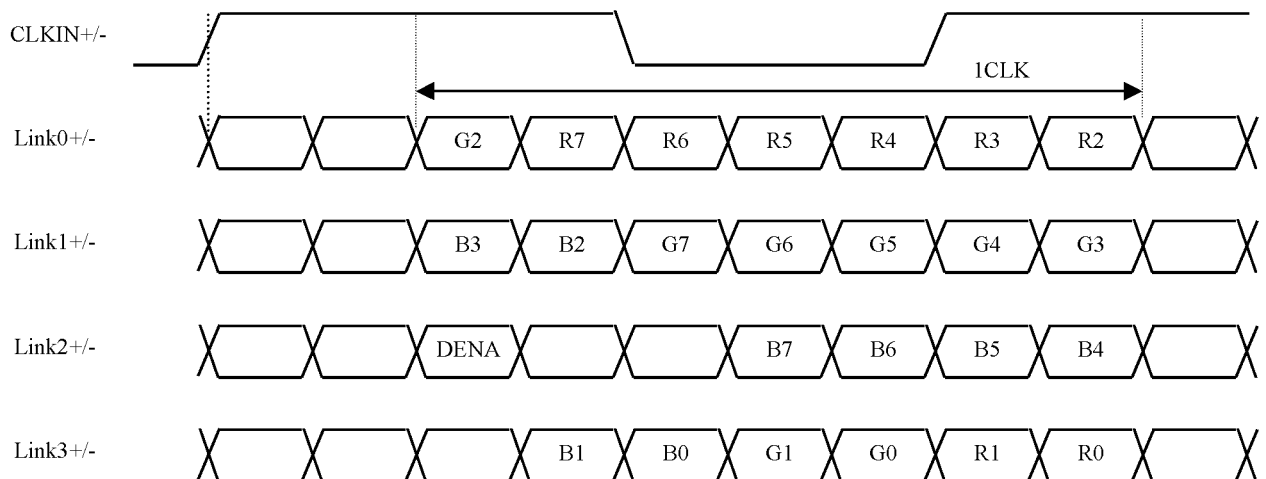

#### c. ISP 8 bit compatibility mode

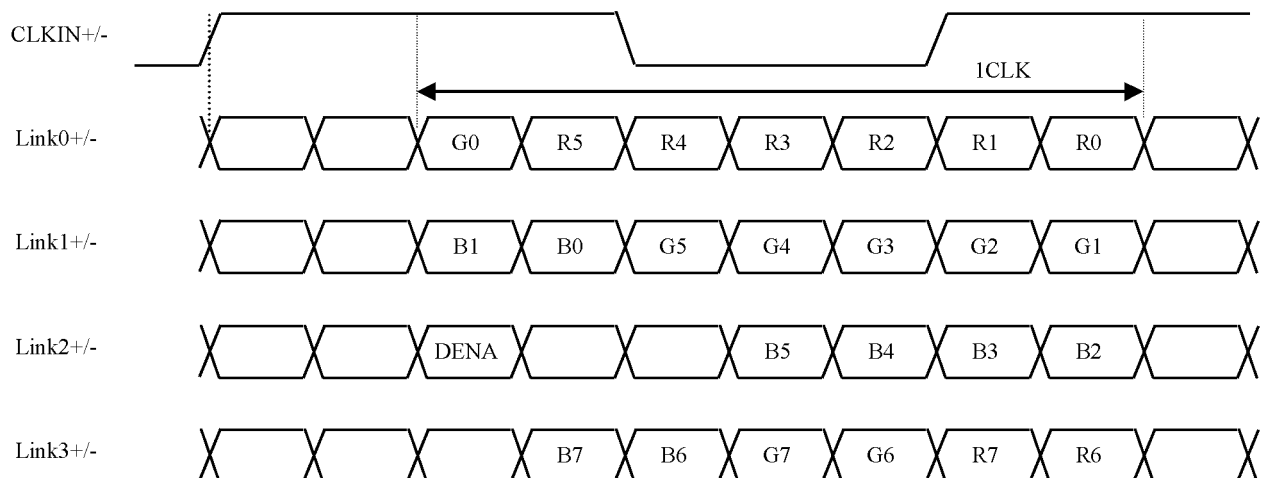

## 6. INTERFACE TIMING

LVDS transmitter input signal

### (1) Timing Specifications

ITEM		SYMBOL	MIN	TYP	MAX	UNIT	
DCLK	Frequency	f <sub>CLK</sub>	25	30.4	45	MHz	
	Period	t <sub>CLK</sub>	22.2	32.9	40	ns	
DENA	Horizontal	Active Time	t <sub>HA</sub>	800	800	800	t <sub>CLK</sub>
		Blanking Time	t <sub>HB</sub>	20	160	--	t <sub>CLK</sub>
		Frequency	f <sub>H</sub>	26.4	31.7	45	kHz
		Period	t <sub>H</sub>	22.2	31.6	37.9	μs
	Vertical	Active Time	t <sub>VA</sub>	480	480	480	t <sub>H</sub>
		Blanking Time	t <sub>VB</sub>	3	48	--	t <sub>H</sub>
		Frequency	f <sub>V</sub>	55	60	75	Hz
		Period	t <sub>V</sub>	13.3	16.7	18.2	ms

[Note]

- 1) DENA (Data Enable) should always be positive polarity as shown in the timing specification.
- 2) DCLK should appear during all invalid period.
- 3) LVDS timing follows the timing specifications of LVDS receiver IC: THC63LVDF84B(Thine).
- 4) In case of blanking time fluctuation, please satisfy following condition.

$$t_{VBn} > t_{VBn-1} - 3(t_H)$$

## (2) Timing Chart

### a. Horizontal Timing Chart

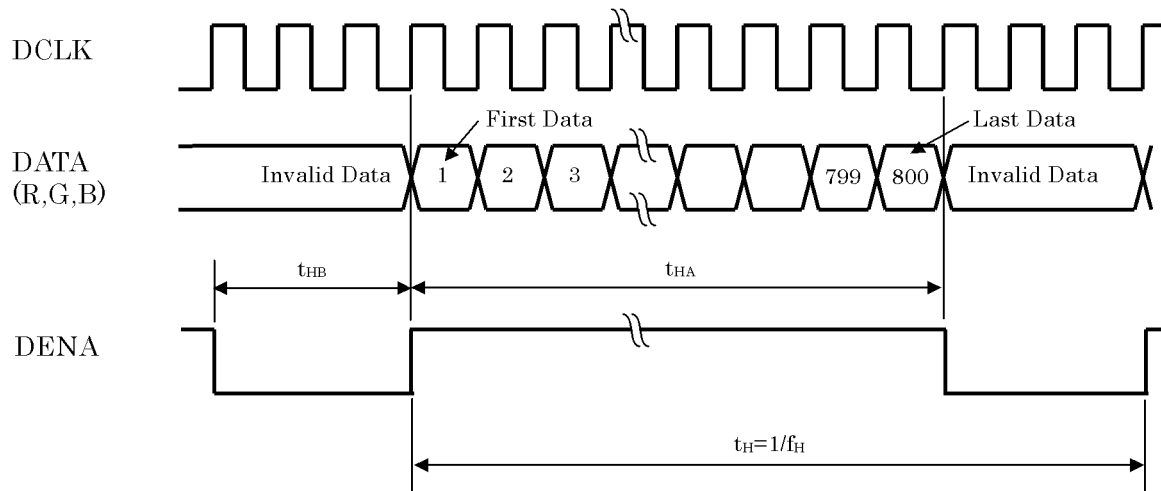

### b. Vertical Timing Chart

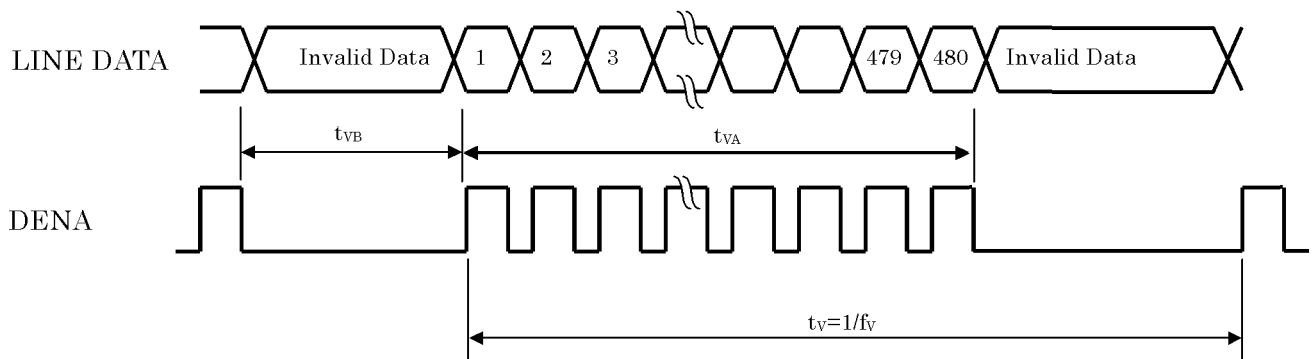

(3) Color Data Assignment

a. 6 bit input

COLOR		INPUT DATA																	
		R DATA						G DATA						B DATA					
		R5	R4	R3	R2	R1	R0	G5	G4	G3	G2	G1	G0	B5	B4	B3	B2	B1	B0
		MSB					LSB	MSB					LSB	MSB					LSB
BASIC COLOR	BLACK	0	0	0	0	0	0	0	0	0	0	0	0	0	0	0	0	0	0
	RED(63)	1	1	1	1	1	1	0	0	0	0	0	0	0	0	0	0	0	0
	GREEN(63)	0	0	0	0	0	0	1	1	1	1	1	1	0	0	0	0	0	0
	BLUE(63)	0	0	0	0	0	0	0	0	0	0	0	0	1	1	1	1	1	1
	CYAN	0	0	0	0	0	0	1	1	1	1	1	1	1	1	1	1	1	1
	MAGENTA	1	1	1	1	1	1	0	0	0	0	0	0	1	1	1	1	1	1
	YELLOW	1	1	1	1	1	1	1	1	1	1	1	1	0	0	0	0	0	0
	WHITE	1	1	1	1	1	1	1	1	1	1	1	1	1	1	1	1	1	1
RED	RED(1)	0	0	0	0	0	1	0	0	0	0	0	0	0	0	0	0	0	0
	RED(2)	0	0	0	0	1	0	0	0	0	0	0	0	0	0	0	0	0	0
	RED(62)	1	1	1	1	1	0	0	0	0	0	0	0	0	0	0	0	0	0
	RED(63)	1	1	1	1	1	1	0	0	0	0	0	0	0	0	0	0	0	0
GREEN	GREEN(1)	0	0	0	0	0	0	0	0	0	0	0	1	0	0	0	0	0	0
	GREEN(2)	0	0	0	0	0	0	0	0	0	0	1	0	0	0	0	0	0	0
	GREEN(62)	0	0	0	0	0	0	1	1	1	1	1	0	0	0	0	0	0	0
GREEN(63)	0	0	0	0	0	0	1	1	1	1	1	1	0	0	0	0	0	0	
BLUE	BLUE(1)	0	0	0	0	0	0	0	0	0	0	0	0	0	0	0	0	0	1
	BLUE(2)	0	0	0	0	0	0	0	0	0	0	0	0	0	0	0	0	1	0
	BLUE(62)	0	0	0	0	0	0	0	0	0	0	0	0	1	1	1	1	1	0
BLUE(63)	0	0	0	0	0	0	0	0	0	0	0	0	1	1	1	1	1	1	

[Note]

1) Definition of gray scale

Color (n) ---n indicates gray scale level.

Higher n means brighter level.

2) Data

1:High, 0: Low

b. 8 bit input

COLOR		INPUT DATA																							
		R DATA								G DATA								B DATA							
		R7	R6	R5	R4	R3	R2	R1	R0	G7	G6	G5	G4	G3	G2	G1	G0	B7	B6	B5	B4	B3	B2	B1	B0
		MSB							LSB	MSB							LSB	MSB							LSB
BASIC COLOR	BLACK	0	0	0	0	0	0	0	0	0	0	0	0	0	0	0	0	0	0	0	0	0	0	0	0
	RED(255)	1	1	1	1	1	1	1	1	0	0	0	0	0	0	0	0	0	0	0	0	0	0	0	0
	GREEN(255)	0	0	0	0	0	0	0	0	1	1	1	1	1	1	1	1	0	0	0	0	0	0	0	0
	BLUE(255)	0	0	0	0	0	0	0	0	0	0	0	0	0	0	0	0	1	1	1	1	1	1	1	1
	CYAN	0	0	0	0	0	0	0	0	1	1	1	1	1	1	1	1	1	1	1	1	1	1	1	1
	MAGENTA	1	1	1	1	1	1	1	1	0	0	0	0	0	0	0	0	1	1	1	1	1	1	1	1
	YELLOW	1	1	1	1	1	1	1	1	1	1	1	1	1	1	1	1	0	0	0	0	0	0	0	0
	WHITE	1	1	1	1	1	1	1	1	1	1	1	1	1	1	1	1	1	1	1	1	1	1	1	1
RED	RED(1)	0	0	0	0	0	0	0	1	0	0	0	0	0	0	0	0	0	0	0	0	0	0	0	0
	RED(2)	0	0	0	0	0	0	1	0	0	0	0	0	0	0	0	0	0	0	0	0	0	0	0	0
	RED(255)	1	1	1	1	1	1	1	1	0	0	0	0	0	0	0	0	0	0	0	0	0	0	0	0
GREEN	GREEN(1)	0	0	0	0	0	0	0	0	0	0	0	0	0	0	0	1	0	0	0	0	0	0	0	0
	GREEN(2)	0	0	0	0	0	0	0	0	0	0	0	0	0	0	1	0	0	0	0	0	0	0	0	0
	GREEN(255)	0	0	0	0	0	0	0	0	1	1	1	1	1	1	1	1	0	0	0	0	0	0	0	0
BLUE	BLUE(1)	0	0	0	0	0	0	0	0	0	0	0	0	0	0	0	0	0	0	0	0	0	0	0	1
	BLUE(2)	0	0	0	0	0	0	0	0	0	0	0	0	0	0	0	0	0	0	0	0	0	0	1	0
	BLUE(255)	0	0	0	0	0	0	0	0	0	0	0	0	0	0	0	0	1	1	1	1	1	1	1	1

[Note]

1) Definition of gray scale

Color (n) ---n indicates gray scale level.

Higher n means brighter level.

2) Data

1:High, 0: Low

(4) Display Position and Scan Direction

D(X,Y) shows the data number of input signal.

SC: Low

SC: High

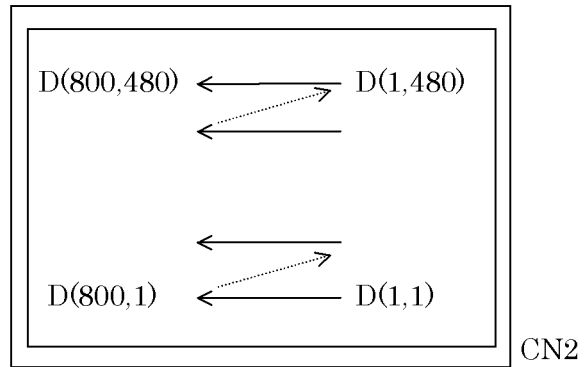
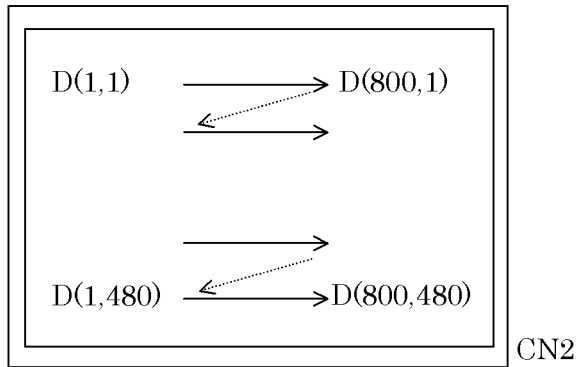

# 7. BLOCK DIAGRAM

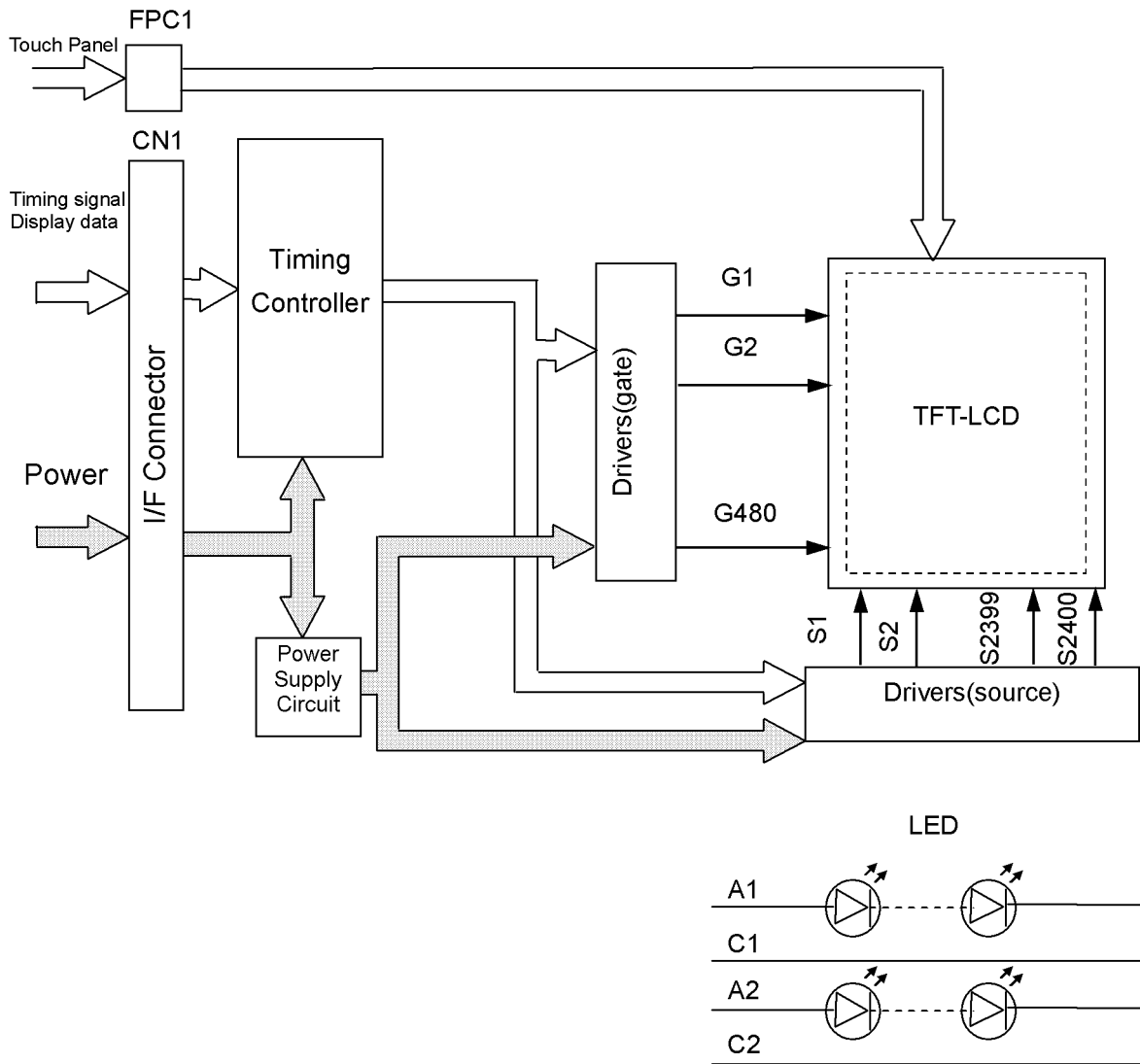

# 8. MECHANICAL SPECIFICATIONS

## (1) Front Side

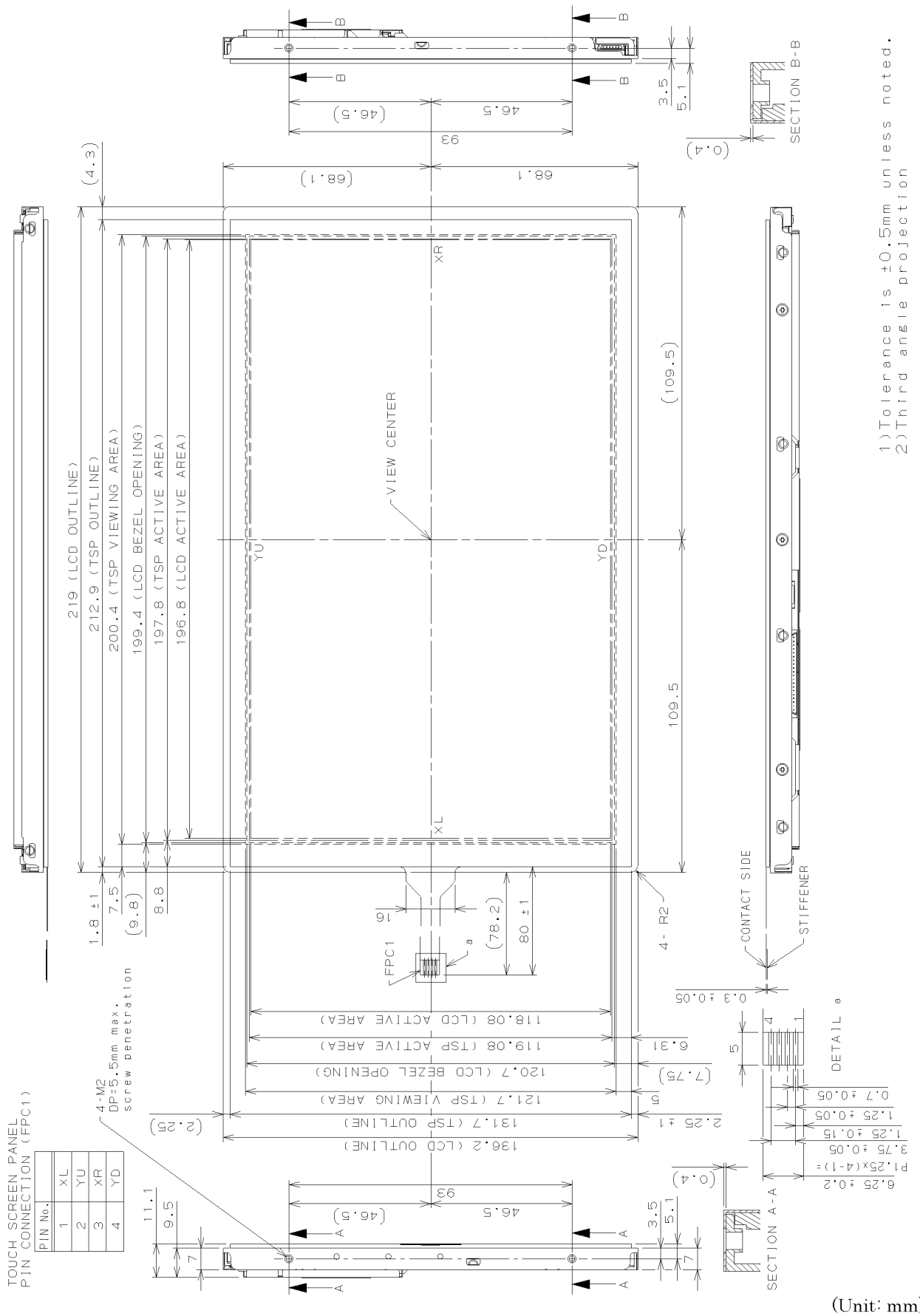

1) Tolerance is ±0.5mm unless noted.  
 2) Third angle projection

(2) Rear Side

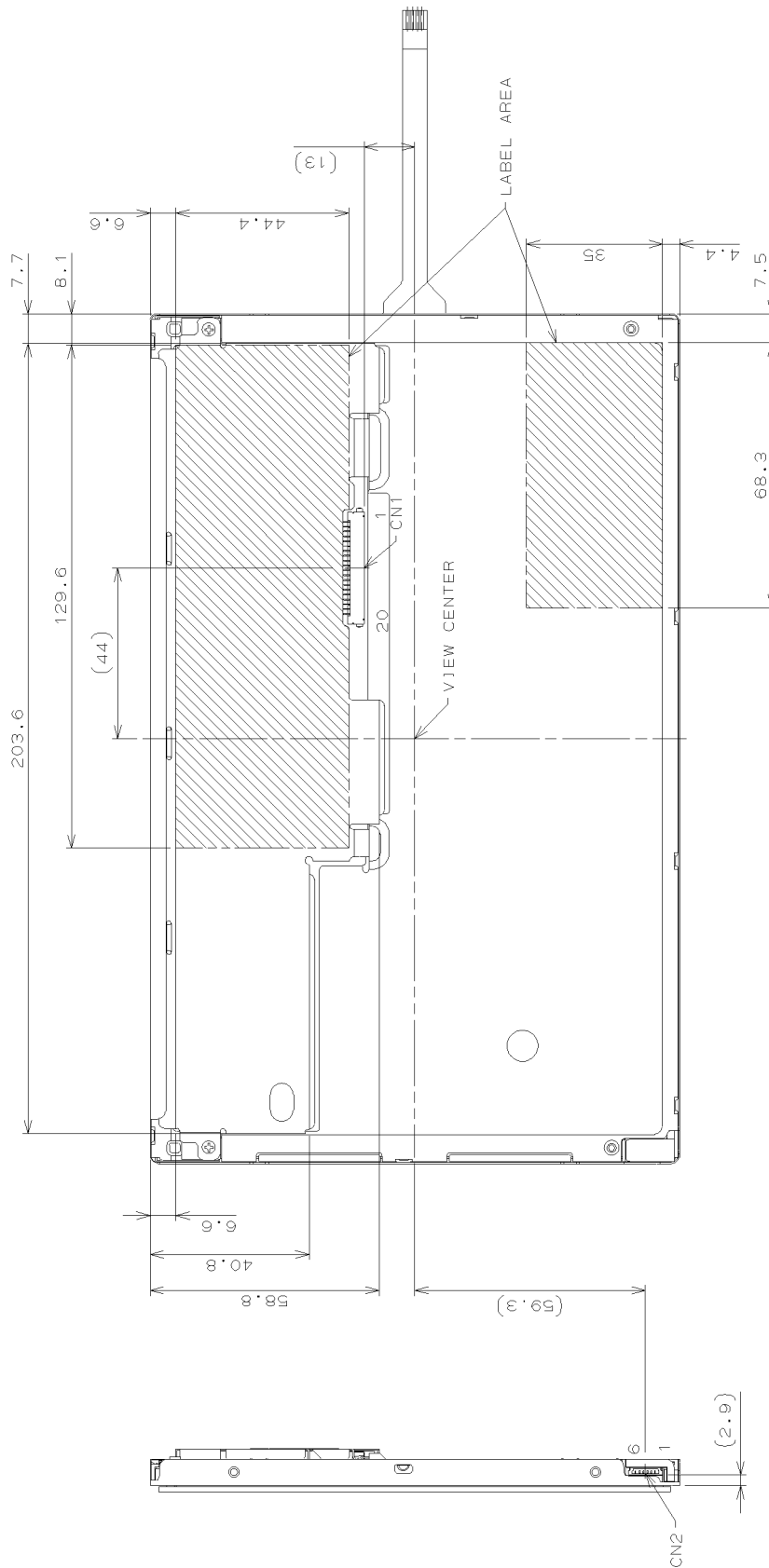

CN1: F1-SE20P-HFE (JAE)  
 CN2: SM06B-SHLS-TF(LF)(SN) (JST)

1) Tolerance is  $\pm 0.5$ mm unless noted.  
 2) Third angle projection

(Unit:mm)

(3) Touch Panel

a. Mechanical Characteristics

ITEM	MIN.	TYP.	MAX.	UNIT	Remarks	
Activation Force	0.05	--	0.8	N	*1)	
Durability	Surface Scratching	Write 100,000	--	--	characters	*2)
	Surface Pitting	10,000,000	--	--	touches	*3)
Surface Hardness	3	--	--	H	JIS K5400, ASTM D3363	

\*1) Stylus pen Input: R4.0 mm silicon pen

\*2) Measurement for Surface area

-Input size 10 × 10 mm

-Input Character A to Z /minute

-Force: 2.45 N

-Stylus: R0.8 mm polyacetal tip

\*3) Pit 10,000,000 hits on the Film with a R4.0 mm silicon pen

-Force: 3 N

-Speed: 2 hits/sec

b. Design Guide

-Avoid the design that Front-case overlap and press on the active area of the touch-panel.

-Give enough gap (over 0.5 mm at compressed) between the front case and touch-panel to protect wrong operating.

-Use a buffer material (Gasket) between the touch-panel and Front-case to protect damage and wrong operating.

-Avoid the design that buffer material overlap and press on the inside of touch-panel viewing area.

-The flexible tail section should be designed to avoid stress from the front case and/or avoid any bending stress to root of flexible tail section.

-Please avoid any strong forces, such as pen input in the area between display area and insulated area (distance: >2mm), because it may cause damage to the film.

-When you handle the product, hold the product by its body. Do not hold by the FPC.

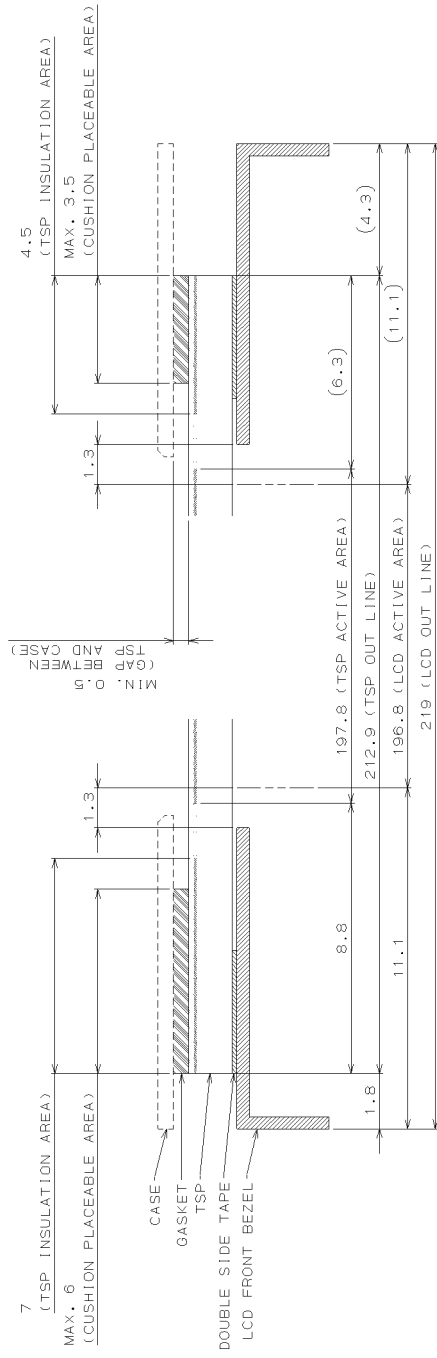
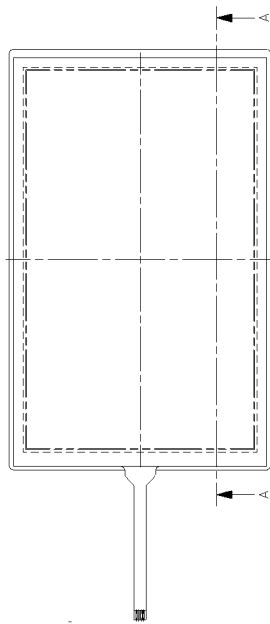

SECTION A - A

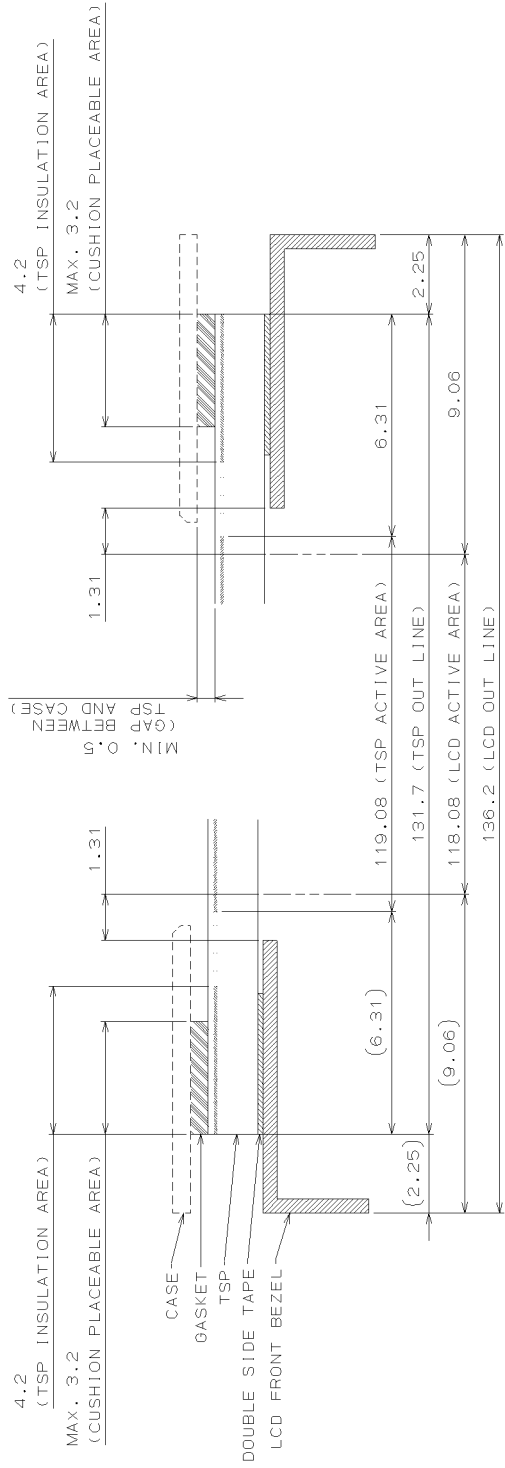
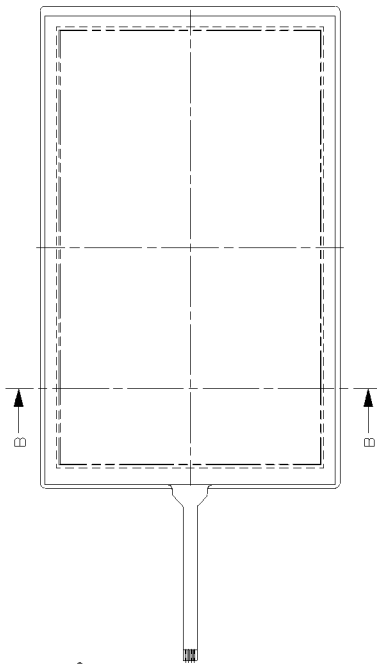

SECTION B-B

## 9. OPTICAL CHARACTERISTICS

Ta=25°C, VCC=3.3V, Input Signals: Typ. values shown in Section 6

ITEM		SYMBOL	CONDITION	MIN	TYP	MAX	UNIT	Remarks
Contrast Ratio		CR	$\theta_V=0^\circ, \theta_H=0^\circ$	490	760	--	--	*1)*2)*5)
Luminance		Lw	$\theta_V=0^\circ, \theta_H=0^\circ$	500	640	--	cd/m <sup>2</sup>	*1)*5)
Luminance Uniformity		$\Delta Lw$	$\theta_V=0^\circ, \theta_H=0^\circ$	--	--	30	%	*1)*3)*5)
Response Time		tr	$\theta_V=0^\circ, \theta_H=0^\circ$	--	4	--	ms	*1)*4)*5)
		tf	$\theta_V=0^\circ, \theta_H=0^\circ$	--	12	--	ms	*1)*4)*5)
Viewing Angle	Horizontal	$\theta_H$	CR $\geq$ 10	-65~65	-80~80	--	°	*1)*5)
	Vertical	$\theta_V$		-45~65	-60~80	--	°	*1)*5)
Image sticking		tis	2 h	--	--	2	s	*6)
Color Coordinates	Red	Rx	$\theta_V=0^\circ, \theta_H=0^\circ$	0.514	0.554	0.594	--	*1)*5)
		Ry		0.303	0.343	0.383		
	Green	Gx		0.319	0.359	0.399		
		Gy		0.525	0.565	0.605		
	Blue	Bx		0.127	0.167	0.207		
		By		0.117	0.157	0.197		
	White	Wx		0.278	0.318	0.358		
		Wy		0.295	0.335	0.375		

[Note]

These items are measured using EZContrast (ELDIM) for viewing angle and CS2000 (Minolta) or equivalent equipment for others under the dark room condition (no ambient light) after more than 30 minutes from turning on the backlight unless noted.

Condition: IF = 80 mA

Measurement method for luminance and color coordinates is as follows.

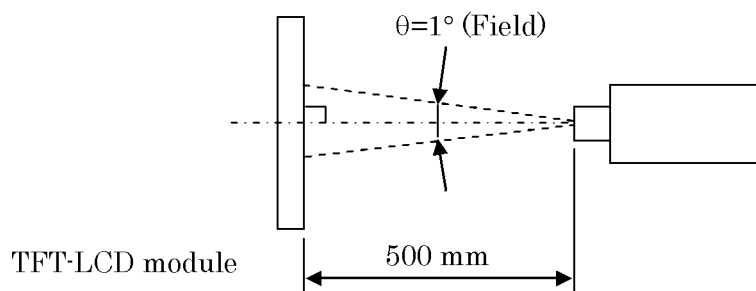

The luminance is measured according to FLAT PANEL DISPLAY MEASUREMENTS STANDARD (VESA Standard).

\*1) Measurement Point

Contrast Ratio, Luminance, Response Time, Viewing Angle, Color Coordinates: Display Center  
 Luminance Uniformity: point 1~5 shown in a figure below

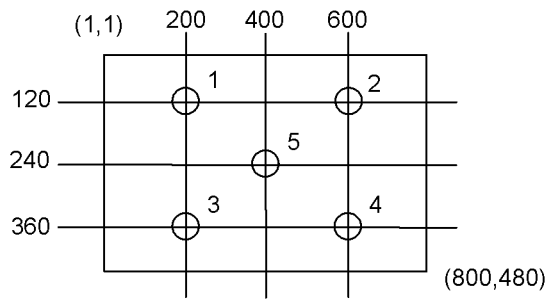

\*2) Definition of Contrast Ratio

$$CR = \text{Luminance with all white pixels} / \text{Luminance with all black pixels}$$

\*3) Definition of Luminance Uniformity

$$\Delta Lw = [Lw(\text{MAX}) / Lw(\text{MIN}) - 1] \times 100$$

\*4) Definition of Response Time

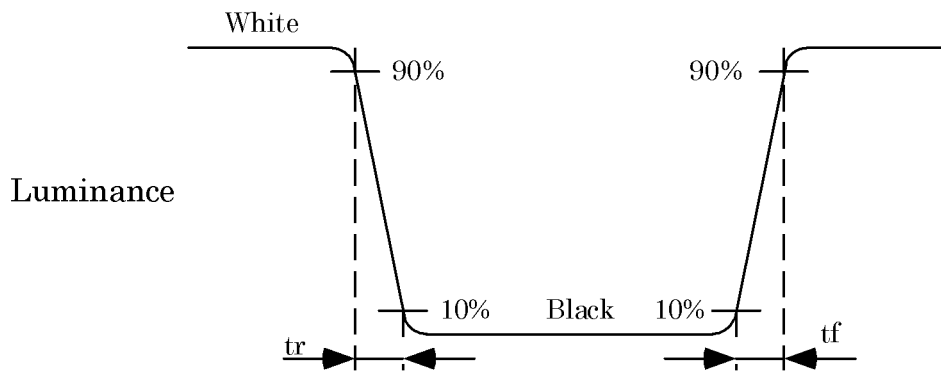

\*5) Definition of Viewing Angle ( $\theta_V$ ,  $\theta_H$ )

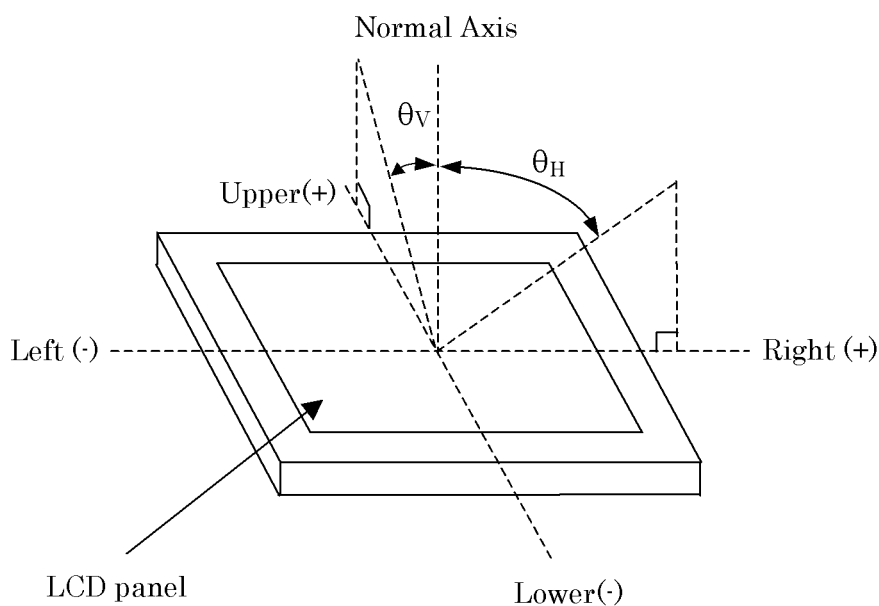

\*6) Image sticking:

Continuously display the test pattern shown in the figure below for two hours. Then display a completely white screen. The previous image shall not persist more than two seconds at 25°C.

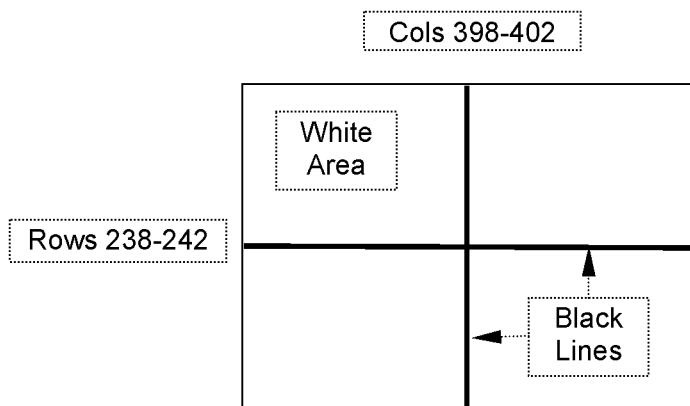

TEST PATTERN FOR IMAGE STICKING TEST

## 10. RELIABILITY TEST CONDITION

### (1) Temperature and Humidity

ITEM	CONDITIONS
HIGH TEMPERATURE HIGH HUMIDITY OPERATION	40°C, 90%RH, 240 h (No condensation)
HIGH TEMPERATURE OPERATION	70°C, 240 h
LOW TEMPERATURE OPERATION	-20°C, 240 h
HIGH TEMPERATURE STORAGE	80°C, 240 h
LOW TEMPERATURE STORAGE	-30°C, 240 h
THERMAL SHOCK (NON-OPERATION)	-30°C (1h) ~ 80°C(1h), 100 cycles

### (2) Shock & Vibration

ITEM	CONDITIONS
SHOCK (NON-OPERATION)	Shock level: 1470 m/s <sup>2</sup> (150G) Waveform: half sinusoidal wave, 2 ms Number of shocks: one shock input in each direction of three mutually perpendicular axes for a total of six shock inputs
VIBRATION (NON-OPERATION)	Vibration level: 9.8 m/s <sup>2</sup> (1.0G) Waveform: sinusoidal Frequency range: 5 to 500 Hz Frequency sweep rate: 0.5 octave /min Duration: one sweep from 5 to 500 Hz in each of three mutually perpendicular axis(each x,y,z axis: 1 hour, total 3 hours)

### (3) ESD Test

ITEM	CONDITIONS
CONTACT DISCHARGE (OPERATION)	150pF, 330Ω, ±8kV, 10 times at 1 sec interval
SIGNAL PIN DISCHARGE (NON-OPERATION)	200pF, 0Ω, ±200V, 10 times at 1 sec interval

### (4) Judgment standard

The judgment of the above tests should be made as follow:

Pass: Normal display image, no damage of the display function. (ex. no line defect)

Partial transformation of the module parts should be ignored.

Fail: No display image, damage of the display function. (ex. line defect)

T-55562D090J-LW-A-ABN Rev.1	OPTREX CORPORATION	Page 25/41
-----------------------------	--------------------	------------

## 12. OTHER FEATURE

This LCD module complies with RoHS\*) directive.

\*) RoHS: Restriction of the use of certain hazardous substances in electrical and electronic equipment

UL1950 certified (UL File# E158720)

## 13. HANDLING PRECAUTIONS FOR TFT-LCD MODULE

Please pay attention to the followings in handling TFT-LCD products:

### (1) ASSEMBLY PRECAUTION

- a. Please mount the LCD module by using mounting hole with a screw clamping torque less than 0.2 Nm. Please do not bend or wrench the LCD module in assembling. Please do not drop, bend or twist the LCD module in handling.
- b. Please design display housing in accordance with the following guide lines.
  - (a) Housing case must be designed carefully so as not to put stresses on LCD and not to wrench module.
  - (b) Under high temperature environment, performance and life time of LED may heavily shorten. When you design with our LCD product, please consider radiating heat and ventilation for good heat management.
  - (c) Keep sufficient clearance between LCD module back surface and housing when the LCD module is mounted. Approximately 1.0mm of the clearance in the design is recommended taking into account the tolerance of LCD module thickness and mounting structure height on the housing.
  - (d) When some parts, such as, FPC cable and ferrite plate, are installed underneath the LCD module, still sufficient clearance is required, such as 0.5mm. This clearance is, especially, to be reconsidered when the additional parts are implemented for EMI countermeasure.
  - (e) Design the LED driver location and connector position carefully so as not to give stress to LED backlight cable and flexible tail.
  - (f) Keep sufficient clearance between LCD module and the others parts, such as inverter and speaker so as not to interfere the LCD module. Approximately 1.0 mm of the clearance in the design is recommended.
  - (g) To avoid local elevation/decrease of temperature, considering location of heating element, heat release, thermal design should be done.
- c. Please do not push or scratch touch panel surface with anything hard. And do not soil LCD panel surface by touching with bare hands.
- d. Do not use or store the product under a condition where the product will be exposed to water, organic solution or acid.
- e. Please wipe off touch panel surface with absorbent cotton or soft cloth in case of it being soiled.
- f. Touch panel glass edge is not rounded. Please take care in handling to avoid injury.
- g. Please do not take a LCD module to pieces and reconstruct it. Resolving and reconstructing modules may cause them not to work well.

- h. Please do not touch metal frames with bare hands and soiled gloves. A color change of the metal frames can happen during a long preservation of soiled LCD modules.
- i. Please handle metal frame carefully because edge of metal frame is very sharp.
- j. Please connect the metal frame of LCD module to GND in order to minimize the effect of external noise and EMI.
- k. Be sure to connect the cables and the connectors correctly.

## (2) OPERATING PRECAUTIONS

- a. Please be sure to turn off the power supply before connecting and disconnecting signal input cable.
- b. Please do not change variable resistance settings in LCD module. They are adjusted to the most suitable value. If they are changed, it might happen LCD does not satisfy the characteristics specification.
- c. The interface signal speed is very high. Please pay attention to transmission line design and other high speed signal precautions to satisfy signal specification.
- d. Condensation might happen on the surface and inside of LCD module in case of sudden change of ambient temperature. Do not use touch panel when there is condensation. It could cause touch panel failure.
- e. Please pay attention not to display the same pattern for very long time. Image sticking might happen on LCD. Although image sticking may disappear as the operation time proceeds, screen saver function is recommended not to cause image sticking.
- f. Please obey the same safe instructions as ones being prepared for ordinary electronic products.

## (3) PRECAUTIONS WITH ELECTROSTATICS

- a. This LCD module use CMOS-IC on circuit board and TFT-LCD panel, and so it is easy to be affected by electrostatics. Please be careful with electrostatics by the way of your body connecting to the ground and so on.
- b. Please remove protection film very slowly from the surface of touch panel to prevent from electrostatics occurrence.

## (4) STORAGE PRECAUTIONS

LCD should be stored in the room temperature environment with normal humidity. The LCD inventory should be processed by first-in first-out method.

## (5) SAFETY PRECAUTIONS

- a. When you waste damaged or unnecessary LCDs, it is recommended to crush LCDs into pieces and wash them off with solvents such as acetone and ethanol, which should later be burned.
- b. If any liquid leaks out of a damaged glass cell and comes in contact with the hands, wash off thoroughly with soap and water.
- c. Be sure to turn off the power supply when inserting or disconnecting the LED backlight cable.
- d. LED driver should be designed carefully to limit or stop its function when over current is detected on the LED.

## (6) OTHERS

- a. A strong incident light into LCD panel may cause deterioration to touch panel, polarizer film, color filter, and other materials, which will degrade the quality and performance of display. Please do not expose LCD module under strong Ultraviolet rays for a long time. If using under direct sunlight condition, please test the reliability and performance completely.
- b. For the packaging box handling, please see and obey with the packaging specification datasheet.
- c. Please do not reuse the LED unit which is once removed.